

6" ÷ 16" vertical lineshaft pumps 6-16长轴深井泵

Irrigation systems
Firefighting systems
General industry
Water supply

灌溉系统
消防系统
工业水处理
供水系统



V Robust cast iron construction
坚固的铸铁结构

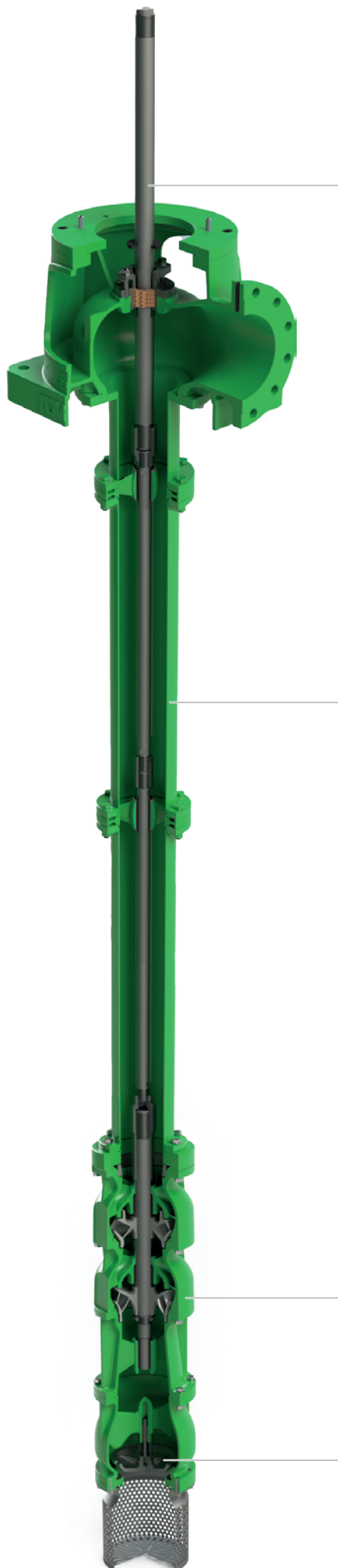

Drive head

Vertical electric motors driver (ME), right angle gear (OR), overgear driven by tractor PTO (OM) and double shaft (ORM) both with right angle gear and with tractor PTO.

驱动头

垂直电机驱动 (ME)、直角齿轮 (OR)、由拖拉机动力输出轴驱动的增速齿轮 (OM) 以及双轴 (ORM)，两者都具备直角齿轮连接和拖拉机动力输出轴驱动。

Lineshaft

Flanged column pipe machined between the centers to ensure perfect alignment.

Lineshaft journal bearings are directly lubricated by the pumped water.

长轴

法兰柱管在中心间加工，确保完美对齐。

轴管轴颈轴承由泵送的水直接润滑。

Pump body

Flanged diffuser use rubber journal bearings to ensure safe operation of the pump shaft.

Impellers are precisely machined and dynamically balanced to reduce vibration and wear.

泵体

法兰式导流壳采用橡胶轴颈轴承，确保泵轴的安全运行。

叶轮经过精密加工和动态平衡，以减少振动和磨损。

Technical data - 技术参数

Nominal size 尺寸	Capacity max. 最大流量		Head max. 最高扬程		Power max. 最大功率	
	[m ³ /h] - 立方/小时	[US.gpm]	[m] - 米	[ft]	[kW]	[HP]
6" ÷ 16"	1200	5300	310	1000	200	270

Footvalve

Includes strainer to restrict entry of foreign objects during operations.

底阀

包括过滤器，用于在操作过程中限制异物进入。

Twinner System® 系统



With the special two halves flange it is possible to easily operate on gland packing box without removing shaft support.

采用特殊的两个法兰，可以在不拆卸轴支撑的情况下轻松操作更换压盖填料环。

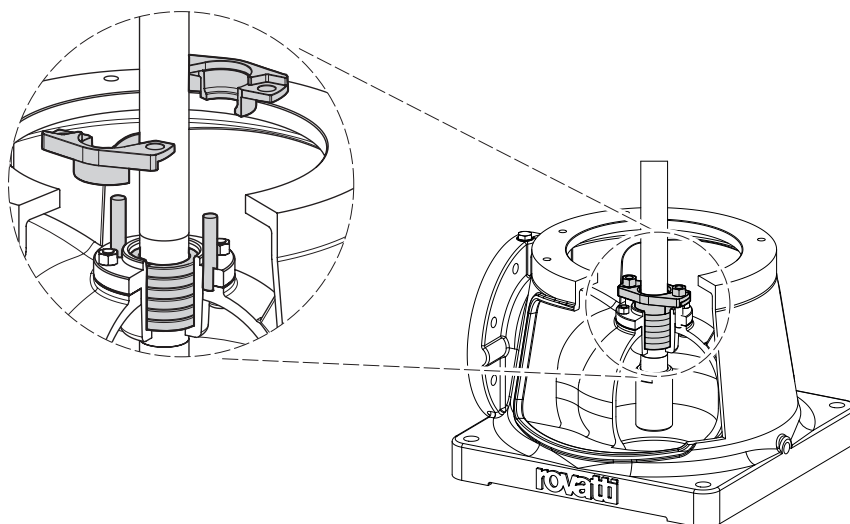

The V series vertical lineshaft pumps are designed to operate also with water level fluctuations and submerged impellers allow the pump to be started without need of priming.

V系列长轴深井泵设计用于在水位波动的情况运行，且叶轮浸没，使得泵无需引水即可启动。

Quality assurance

Rovatti Pompe Quality Control is a continuous process. It begins from the quotation phase and continues throughout the ordering phase, manufacturing process, customer follow-up and service. Product is inspected at multiple stages throughout the manufacturing process to ensure the best quality product.

质量保证

的质量控制是一个持续的过程，它从报价阶段开始，一直持续到订单阶段、制造过程、客户跟进和服务。在整个制造过程中，产品会在多个阶段进行检验，以确保获得最佳质量的产品。

Completely customizable

It is possible to choose different drive systems for electric motors, diesel engines and tractor PTO. The total unit's floor space requirement is minimal and the lineshaft length can be adjusted for every site-specific needs. Pump bowls are available in a wide range of models and sizes to meet virtually any flow and head combination.

完全可定制

可以选择不同的驱动方式，适用于电机、柴油发动机和拖拉机动力输出轴。整个装置占地面积要求很小，管线轴长度可以根据每个现场的具体需求进行调整。泵壳有多种型号和尺寸可供选择，以满足几乎任何流量和扬程的组合。

Maximum reliability

All drive heads are equipped with a device that blocks transmission shaft if it is running in the is wrong rotation direction.

可靠性强

所有驱动头都配备一个特殊装置，如果传动轴以错误的方向运行，该装置会阻止传动轴运行。

V series are designed to handle clean water as well as other clean, non-corrosive liquids without solids. Their compact design makes them ideal both in agricultural irrigation systems and numerous industrial applications.

V系列设计用于处理清洁水以及其他清洁、无腐蚀性、无固体的液体。其紧凑的设计使其成为农业灌溉系统和众多工业应用的理想选择。



A powerful team in the world

Since 1952 Rovatti Pompe manufactures, develops and distributes centrifugal pumps for submersible and surface installations constantly asserting itself as a global leader.

The wide range of centrifugal pumps produced, the well-established experience in the field and the continuous production quality improvement summarize the potential fielded by the Company.

While an active research and development program focuses on technological innovations and environmental impact, the design of new production processes, the development of advanced technical solutions and the use of new materials allow the Company to steadily improve the efficiency, reliability and maintenance of all products.

The value of the employees finally complete the driving force behind the entire Rovatti group.

世界上强大的团队

自1952年以来，Rovatti Pompe一直致力于制造、开发和销售潜水泵、深井泵、地面泵，不断成为全球领导者。

生产的离心泵种类繁多，在该领域积累了丰富的经验，不断提高生产质量，总结了公司在该领域的潜力。

质量和创新代表了Rovatti Pompe所有选择的精神，虽然积极的研发计划侧重于技术创新和对环境的影响，但新生产工艺的设计、先进技术解决方案的开发和新材料的使用使公司能够稳步提高所有产品的效率、可靠性和维护性。

员工的价值构成整个Rovatti集团背后的驱动力。

HEADQUARTERS



2000 DIVISION



IPERSOM DIVISION



HEADQUARTERS:

42042 FABBRICO (REGGIO EMILIA)
ITALY
Tel +39 0522 66 50 00
Fax +39 0522 66 50 20
info@rovatti.it
www.rovatti.it

2000 DIVISION:

42047 ROLO (REGGIO EMILIA)
ITALY
Tel +39 0522 66 72 17 / 0522 66 72 25
Fax +39 0522 66 09 79
info@rovatti.it
www.rovatti.it

IPERSOM DIVISION:

42042 FABBRICO (REGGIO EMILIA)
ITALY
Tel +39 0522 66 08 15
Fax +39 0522 66 02 70
info@rovatti.it
www.rovatti.it

苏州罗瓦迪水泵有限公司

中国江苏省太仓市娄江北路8号B06
邮编: 215400
电话: +86(0)512 - 53375308
传真: +86(0)512 - 53375301
info@rovatti.cn
www.rovatti.cn

SUZHOU ROVATTI PUMPS CO., LTD
Loujiang North Road, 8 ,B06 - 215400
Taicang Economic Development Area
Jiangsu Province - China
Tel: +86 (0) 512 - 53375308
Fax: +86 (0) 512 - 53375301
info@rovatti.cn
www.rovatti.cn

